



520100

KS-retractable plastic skeg Pro, complete



520101

KS-retractable plastic skeg Pro, plain
(without flange in box)

PRODUCT CODE	PRODUCT NAME	ID
520110	KS Skeg blade (inc wire 3mm / 2,5 m)	1
520120	KS Skeg box Pro, with flange (material ABS), inc PA-tube 6/4	2
520121	KS Skeg box Pro, without flange (material ABS), inc PA-tube 6/4	2b
520125	Axle for Skeg box (female)	3
520125	Axle for Skeg box (male)	4
520131	KS Skeg control box (material: ABS)	5
520132	KS Skeg control rail	6
520133	KS skeg control knop	7
520134	KS Skeg control plug	8
473309	Selftapping screw (2,9 x 9,5mm) A4, DIN 7983	9
453412	Screw M4 x 12 mm A4, DIN 966	10
465140	Washer M4, A4, DIN 9021	11
461140	Nut M4, A4, DIN 934	12
490600	O-ring (4,47 x 1,78 mm)	13

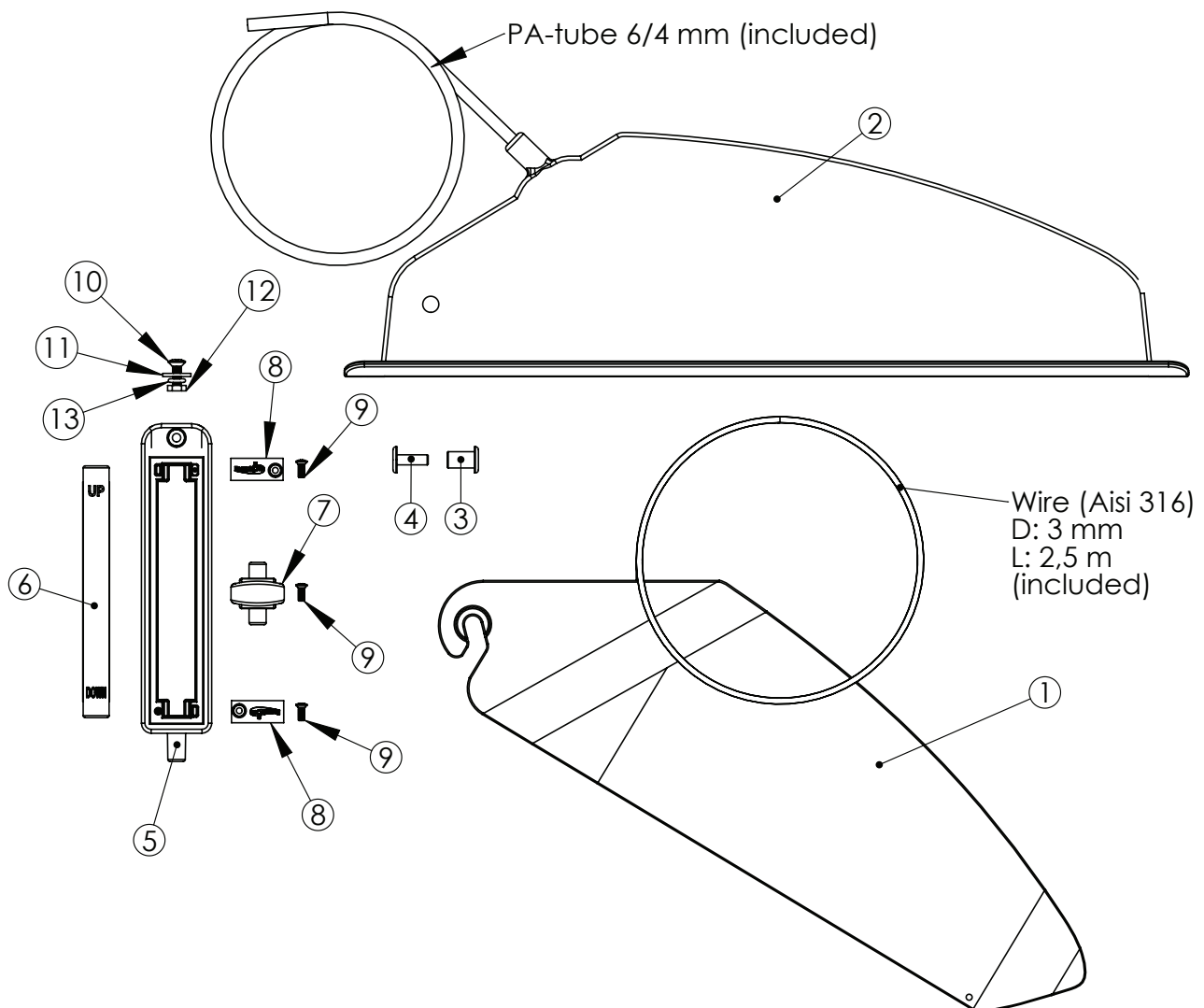

EXPLODED VIEW

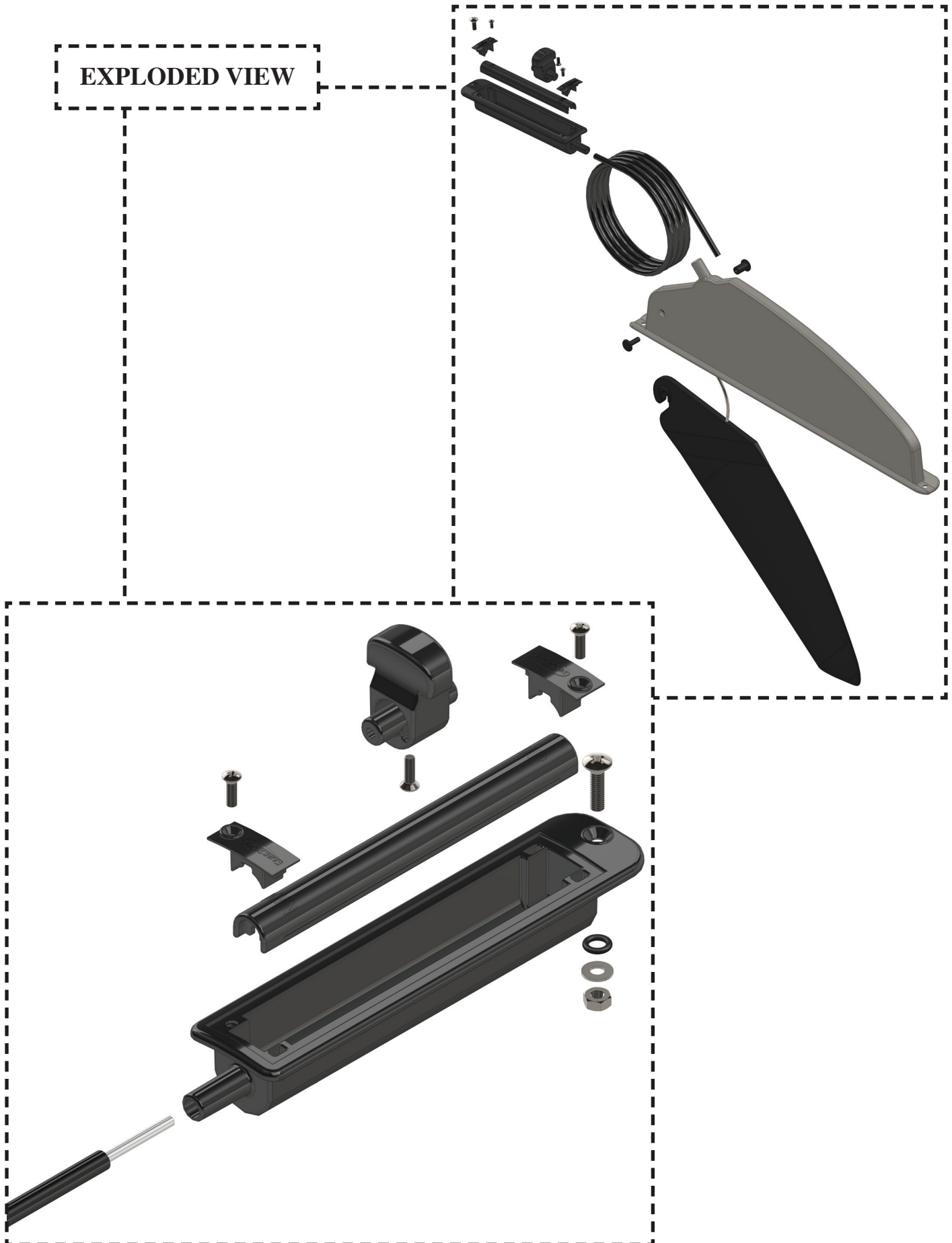

Skeg box, base dimensions

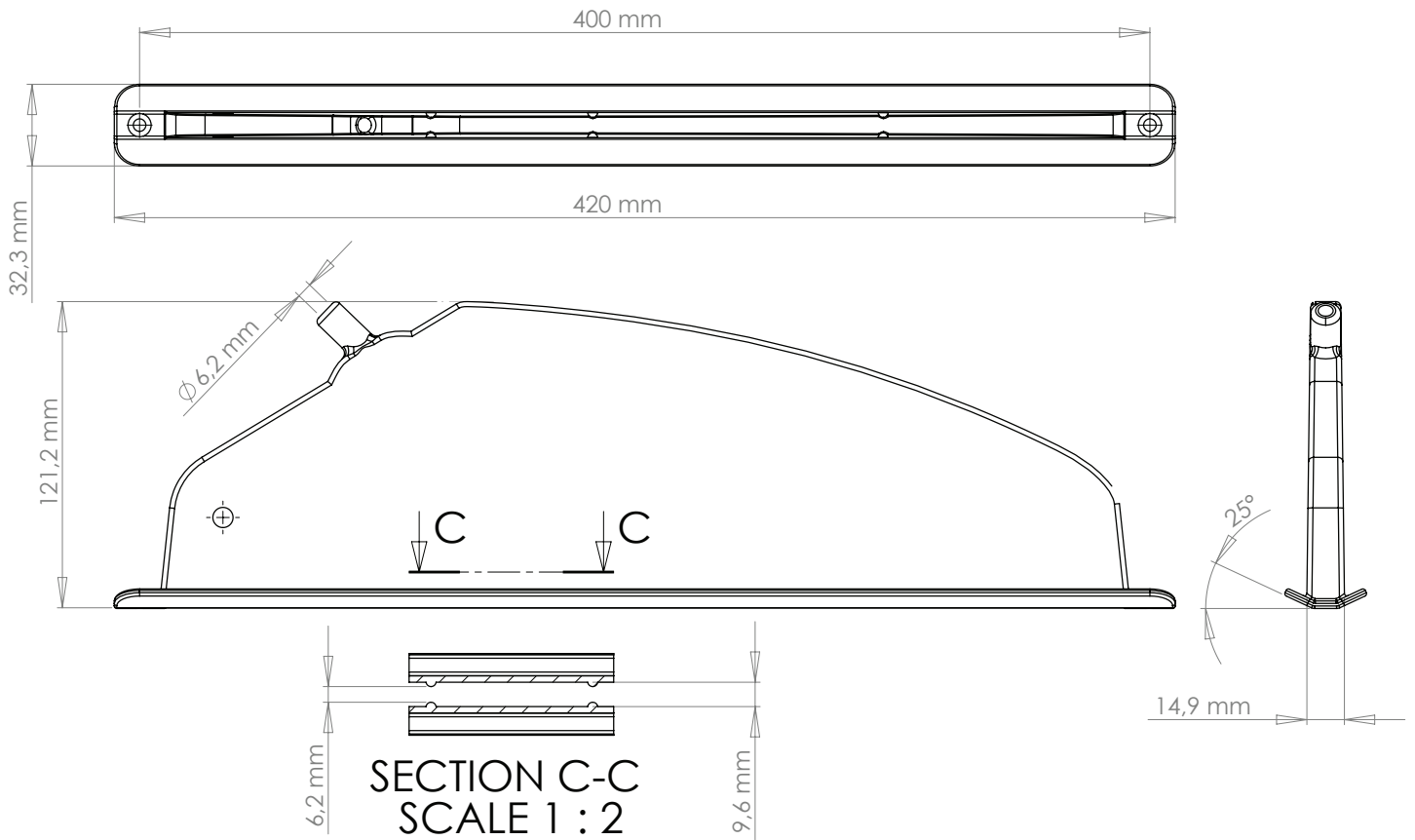

Skeg control unit, base dimensions

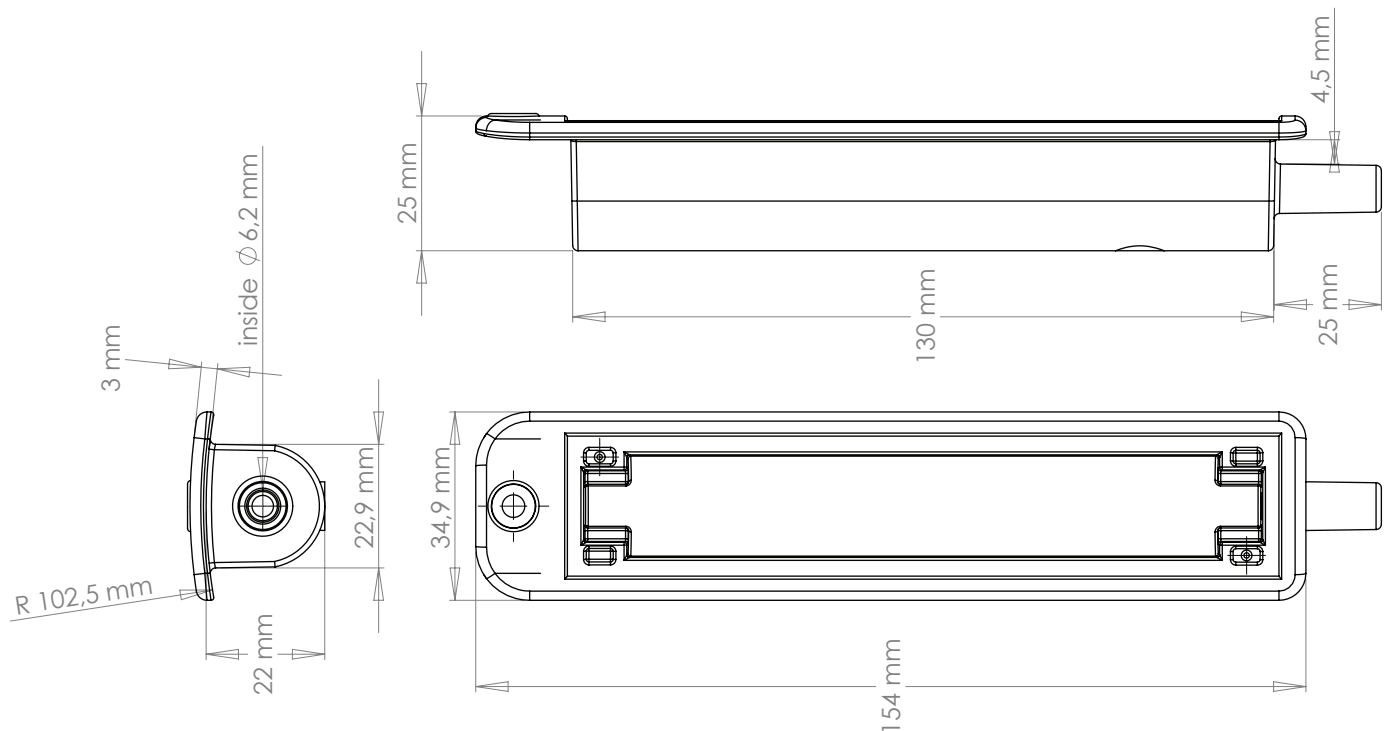

Skeg box (with flange) installation

The skeg box with flange is meant to be installed into a recess from outside and underneath into the kayak hull.

This assembly works well with both composite and PE kayaks.

(in PE kayaks, jointment is recommended to be secured with screws).

Outside fitting is simple and secure fitting method which has low labour time in production. It is a good way to fit the skeg box to a wooden kayak as well. Low skeg recess supports the box well and it's easy to infuse, vacuum or rotation mould. In outside fitting skeg box continues all the way down in the operation area and supports the skeg blade properly.

Clear downward draft in skeg box also empties efficiently the box of any obstacles. In case of hazard, skegbox can be replaced anytime later.

Inside core is recommended to use (thickness 6,2 mm) when attaching the box.

The skeg box is made of ABS. It can be attached with polyester or epoxy resin or with Sikaflex-221 glue after gluing surface is treated with primer (e.g. with sika ABS primer 215 or 290DC). More information from www.sika.com

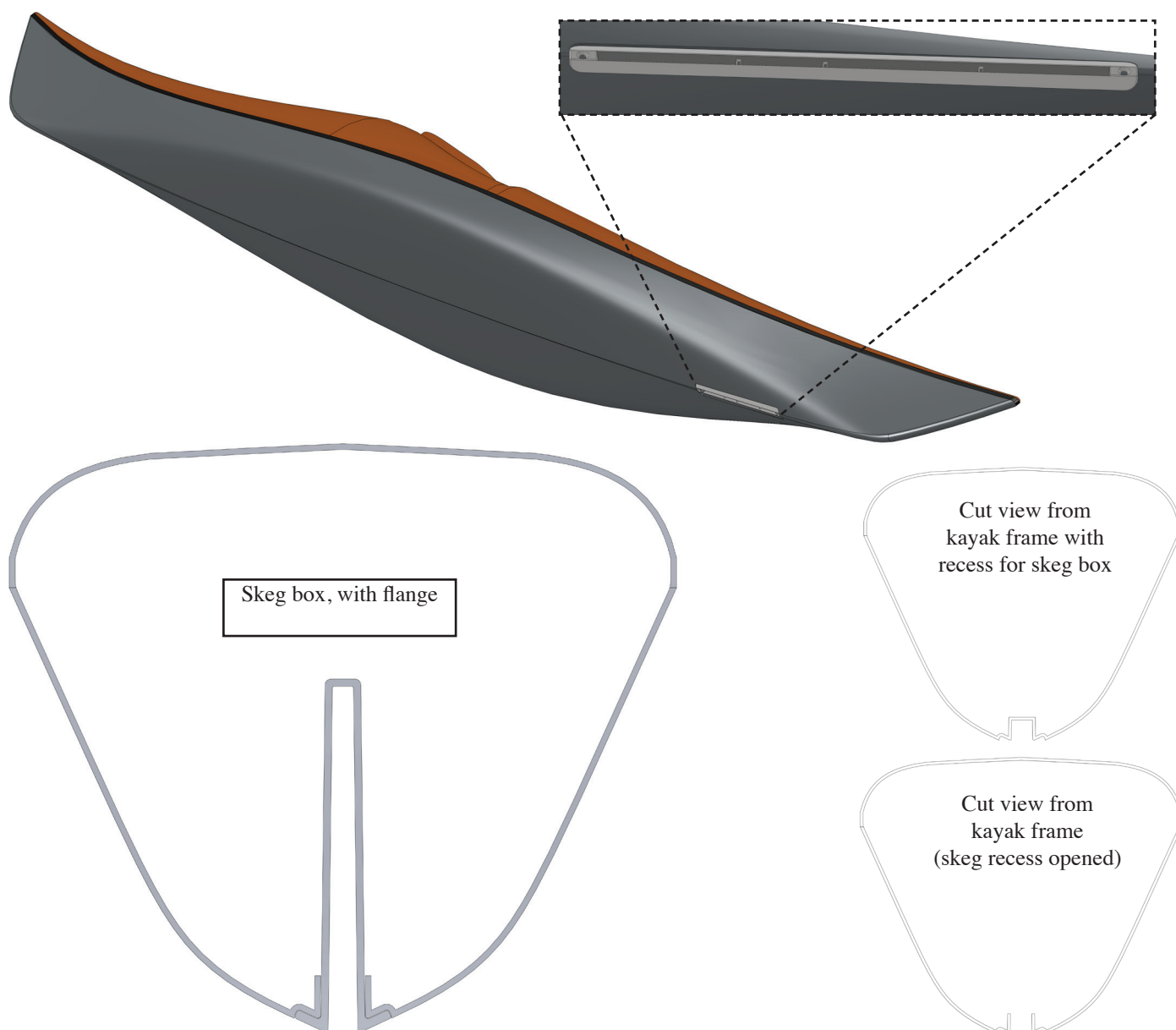

Skeg box (without flange) installation

1. The skeg box without the flange is designed to be installed from inside to the kayak. This assembly method works well in both production and retrofit models.

In production it makes sense to build integrated inner aluminium core to the mould. Skeg box can be placed over it and laminated to the hull without additional labour work.

When skeg box without flange is retrofitted cut open the hull from planned skeg area and build some temporary inner core tool to help assembly. Supporting core can be placed from outside of the kayak underneath to hold the skeg box on its place while laminated. Inner core also ensures that box has correct width and shape after attachment.

- Inside core is highly recommended to use (core thickness 6,2 mm)

- The skeg box is made of ABS. It can be attached with polyester or epoxy resin or with Sikaflex-221 glue after gluing surface is treated with primer (e.g. with sika ABS primer 215 or 290DC). More information www.sika.com

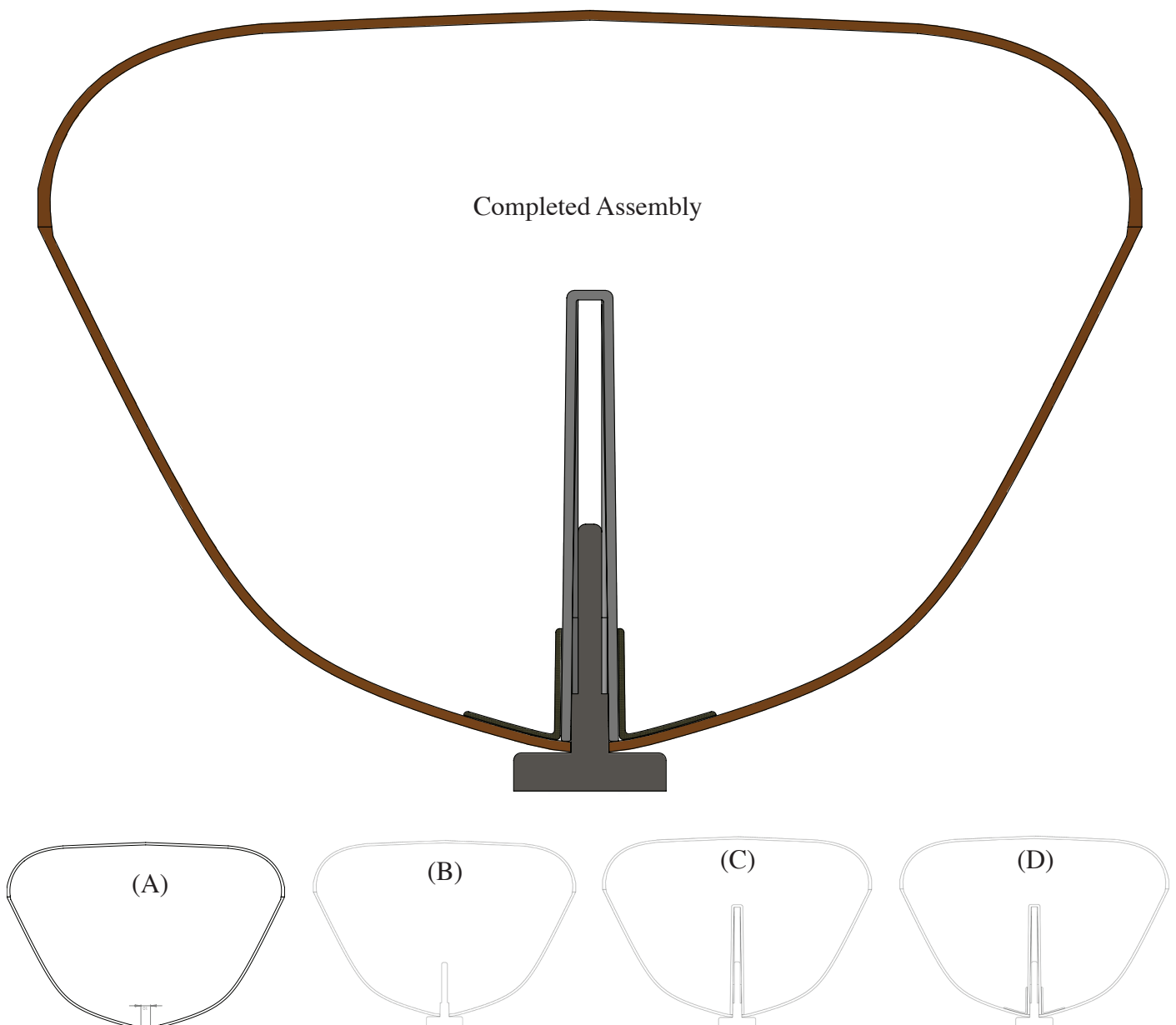

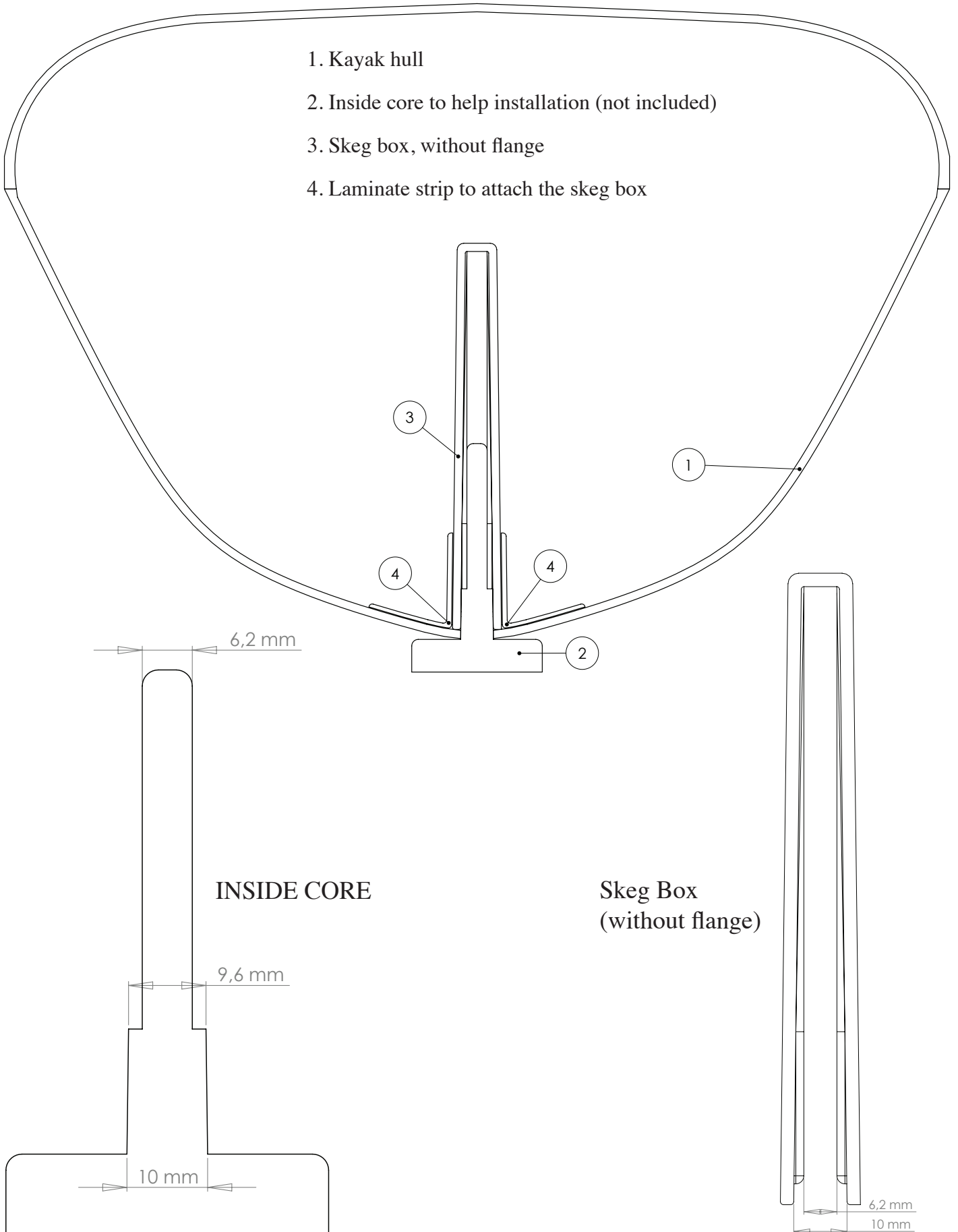

Complete the skeg system assembly

Glue the PA-tube to the skeg control unit.
Roughen gluing surfaces of both parts to get good bonding.

Tested glues for e.g. are:
Araldite 2011, slowly drying epoxy glue (www.huntsman.com)
Loctite 4062 (www.loctite.com)

Fix the PA-tube properly and straight lined to kayak frame so that it can't slide.

Both ends of the tube, close to the control unit and skeg box are the most important to fix well.

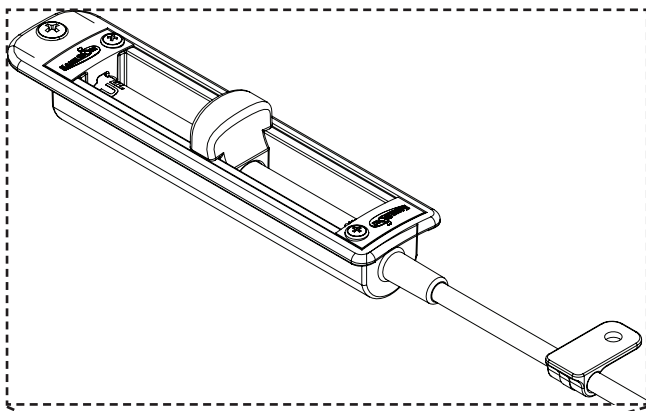

INSTALLING THE SKEG BLADE IN TO THE SKEG BOX

First slide the skeg wire inside in to the PA-tube which is connected between the skeg box and the control unit. (Wire should slide in without any effort). Then attach the skeg blade around the axle. Start sliding the skeg on to the axle so that blade is placed on 90 degrees angle. Follow the axle track in the blade, finally click it on (be caution that you won't damage the skeg box). **When blade is properly around the axle, instead of pushing the blade inside in to the skeg box pull it up from the wire from control unit end!**

(Pushing from blade might kink the wire)

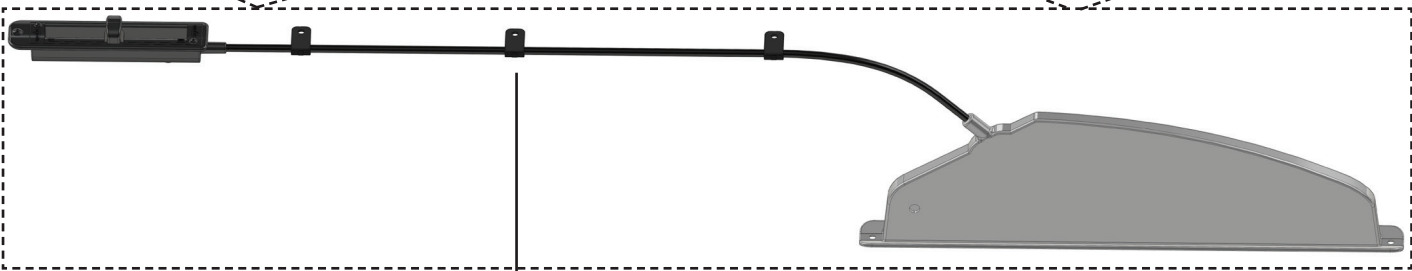
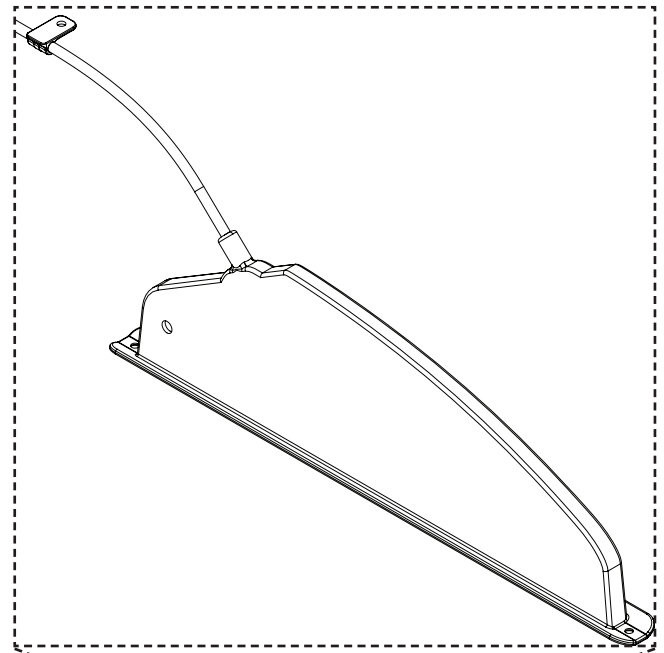

The most simple and advanced way to fix the PA-tube to the kayak frame is Kajak-Sport new KS-pipe clamp, 6 mm (#703220)

Optional



Adjust the skeg angle correctly!

The skeg blade should not come more than 40 degrees out of the skeg box. Any higher angle adjustment increases the risk of blade damage while skeg operating efficiency won't increase.

Adjust correct angle from control unit. Slide control knob at back end of skeg control box (adjustment area). Lower skeg blade on correct 40 degrees angle. Hold knob and wire together while you pull blade up again and tighten the wire lock screw underneath the skeg control knob. (shown more closely on next page)

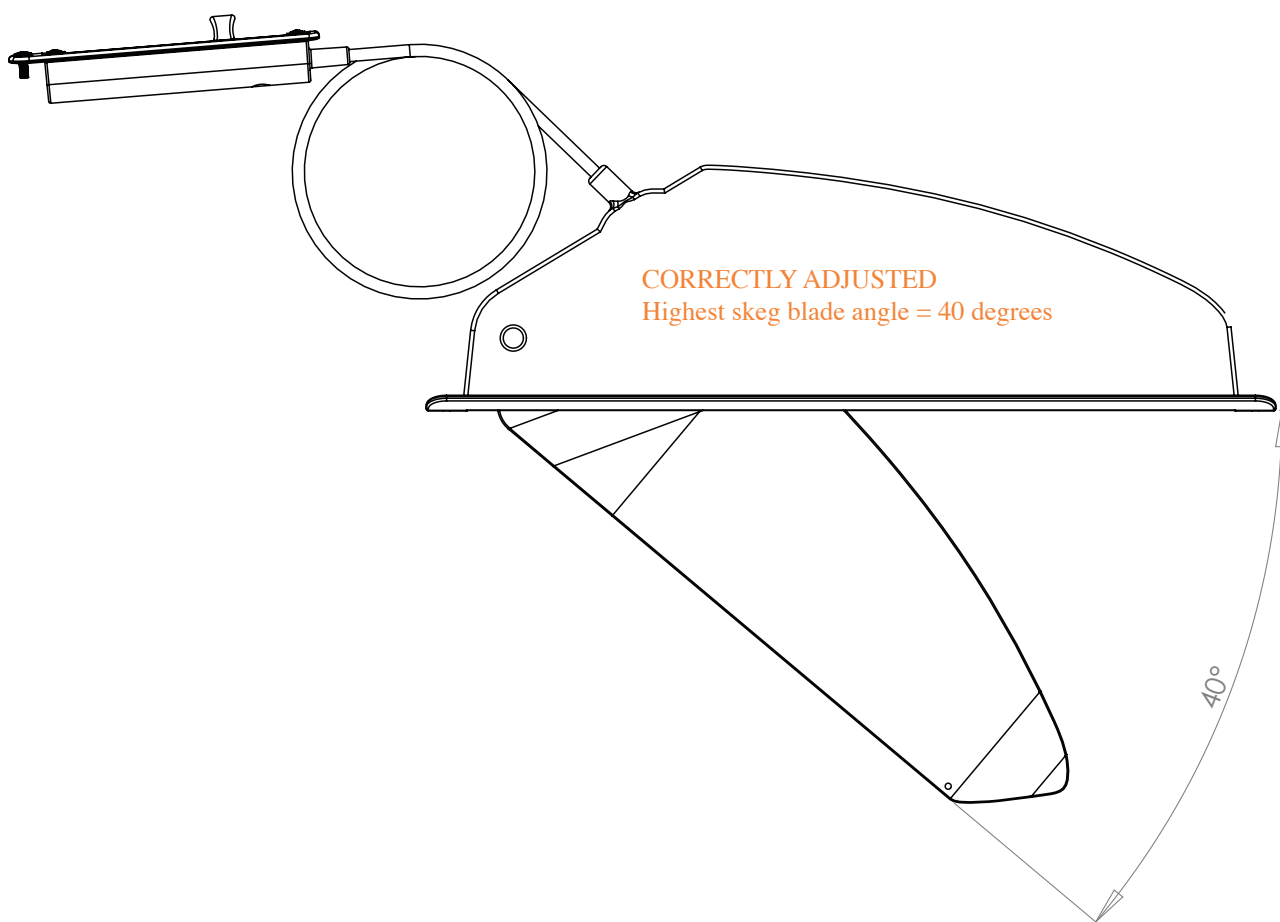

INCORRECTLY ADJUSTED (high angle)

UNEFFICIENTLY ADJUSTED (low angle)

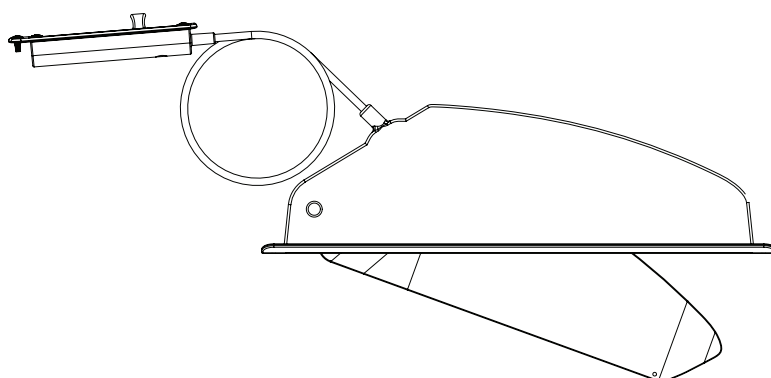
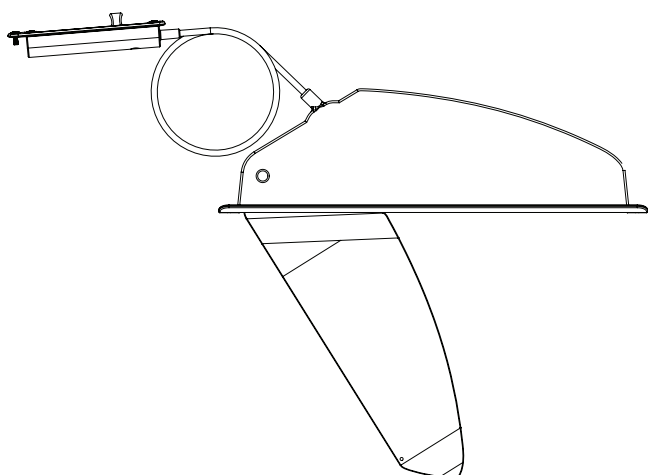

SKEG CONTROL UNIT ASSEMBLY

Thread the skeg wire through the control box wire housing.

Twist the wire upright and thread through the control knob.

Adjust the skeg blade like shown in previous page and tighten the wire locking screw under control knob to get the system fixed

Be caution with the wire of not bending it too much to kink the wire

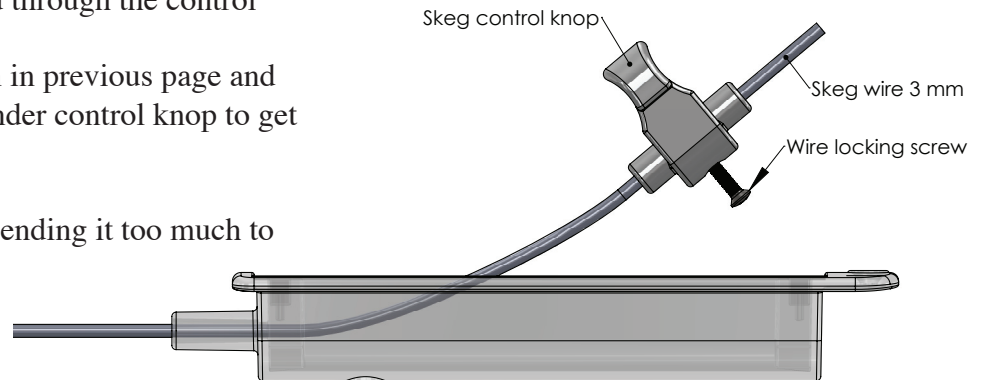

Adjust the skeg blade like said in previous page and tighten the wire locking screw under control knob to get the system fixed properly

Cut the rest of the wire from front of the control knob

Thread control rail through control knob from backside

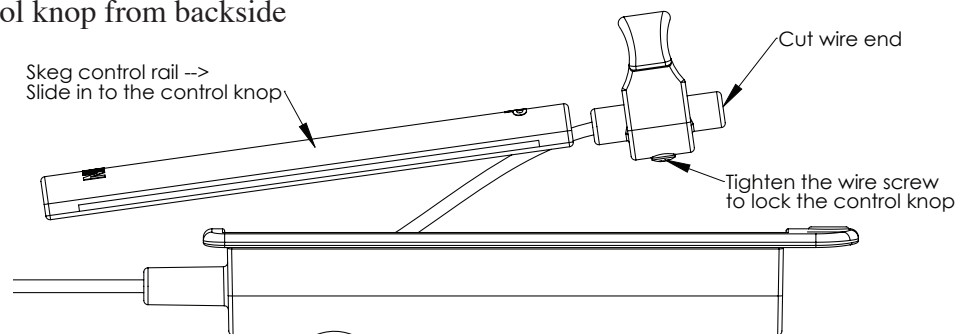

Plush the skec control knop and rail together inside in to the control box on their own place on the middle

Push control plugs on both end to hold on the rail mechanism down and secure with screws

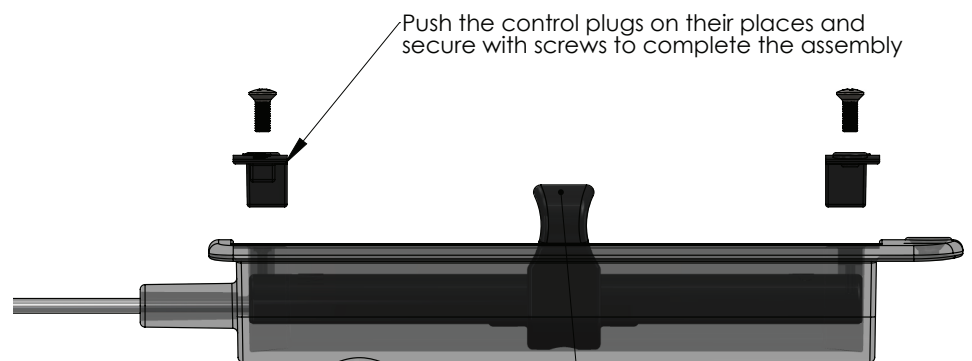

Place the skeg control knop together with rail on it's own place inside in to the skeg control box